

TRICO L

Channel Letter Solutions

Specifications

Viewing Angle	160° Optics
Input Voltage	12VDC
Watts	2.4w/mod (2.4w/ft.)
Colors	RGB/W
Modules/Foot	1/ft. fully stretched
Protection Grade	IP67
Packaging	60pcs/chain, 60pcs/bag 10 bags/outer carton
Warranty	5 Year (Product) / 1 Year (Labor)
Operating Temp.	-40° ~ +60 °C / -40° ~ +140 °F
Storage Temp.	-40° ~ -70 °C / -40° ~ +158 °F



IP67 c  us
E344189



Benefits

- Quick Installation System (QIS) enabled.
- Designed for Small to large Channel letters.
- UV and IR Protected
- L80 rating of 50,000 hours
- 3M double face tape and mechanical mounting options.

Drawings

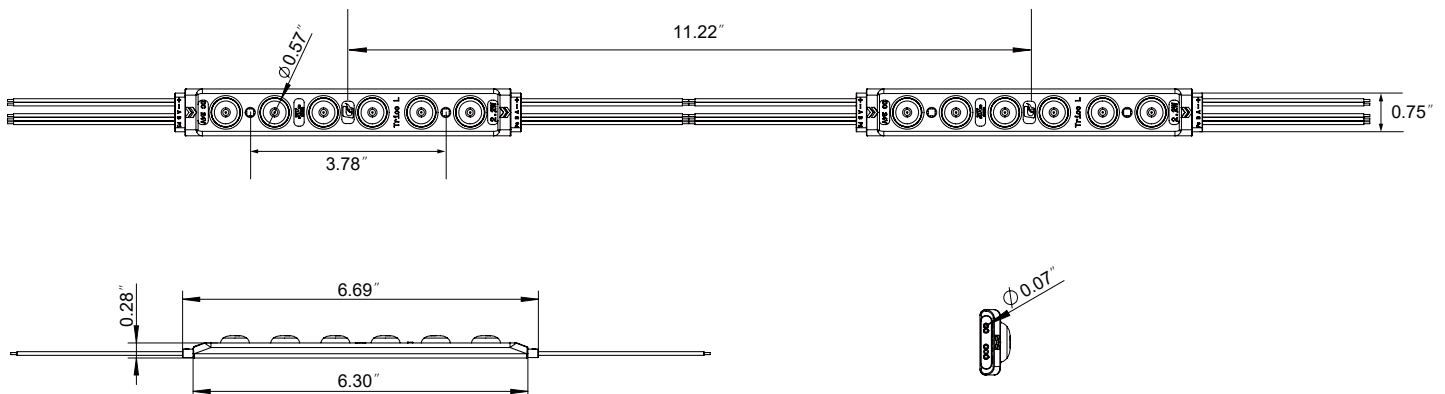

QIS Connection Diagram

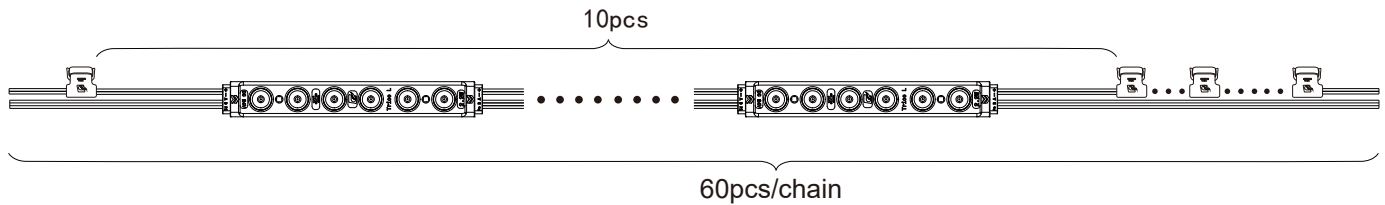

1. Start to connect before the first module (start at both ends).
2. Every additional connector is after every 10 module.
3. Can cascade every 60 module with center pointing.
4. Using the most middle on the chain as the position of connection.

Sign Cabinet Installation Overview

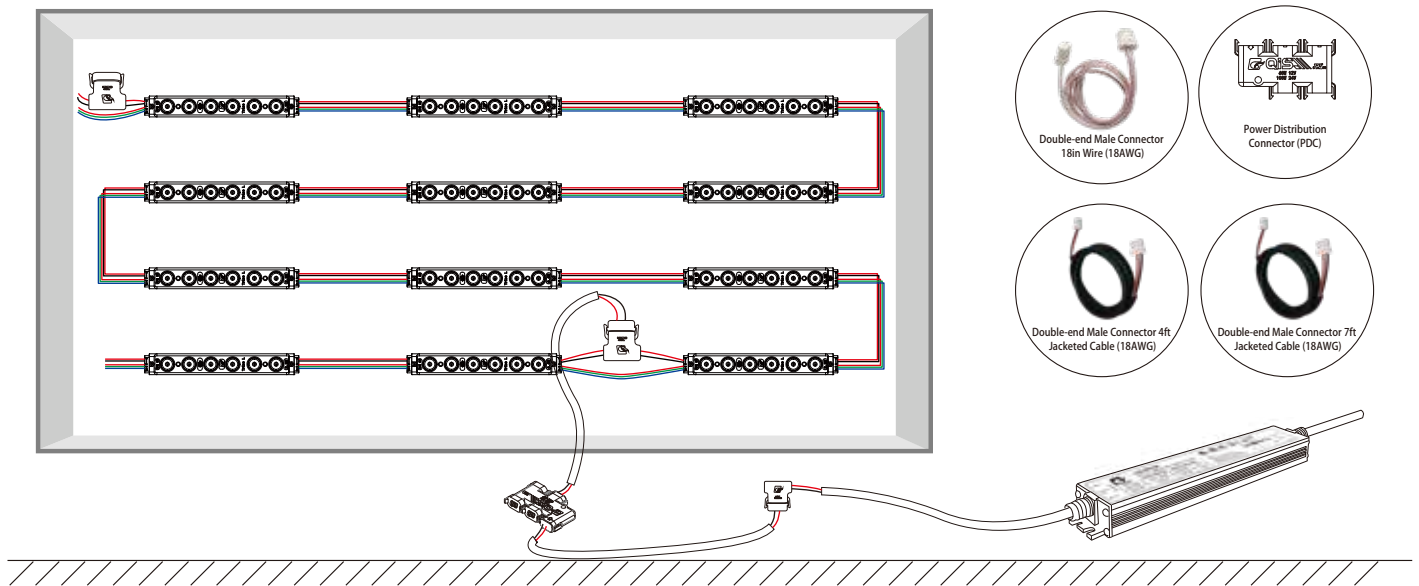

Quick Installation System Guide:

1. Install the modules inside cabinet
2. Use Double Male connector with 4ft lead to jump wire different string of modules
3. Wire Double Male connector with 7ft lead to the power supply.